

CAROUSEL

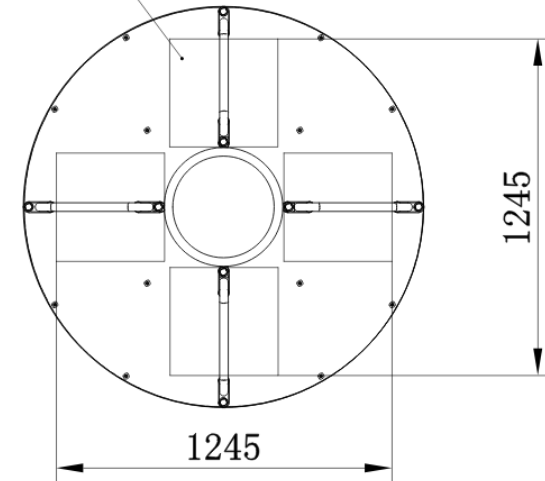

Carousels

- (a) Standard Carousels - The impact area around carousels shall have a critical fall height of at least 100mm
- (b) Distance from underside of carousel to soft fall should be between 60-110mm or greater than 400mm

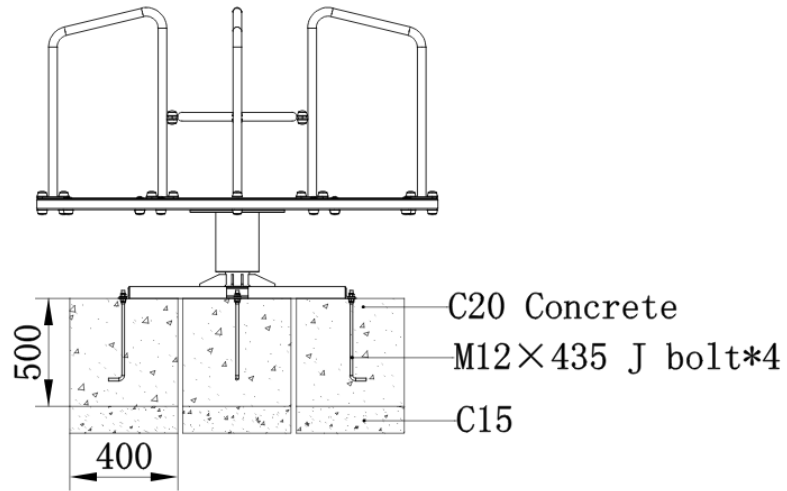
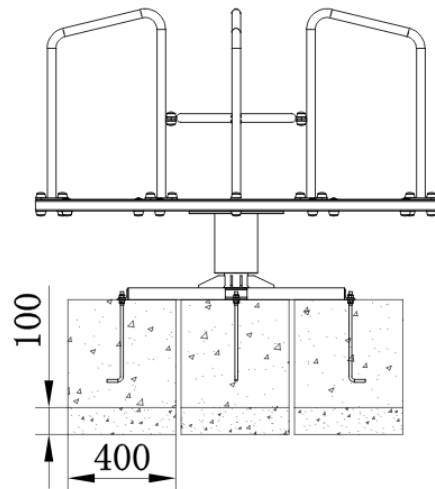

STANDARD CAROUSELS, ROTATING NETS & REVOLVING RINGS

The impact area shall extend at least 2000 mm from the outside of the carousel.

Note: The impact area of these types of carousel cannot overlap the impact area of another item of equipment.

